

### 短节距倍速输送链链轮

Short pitch Speed-fold conveyor chain sprocket

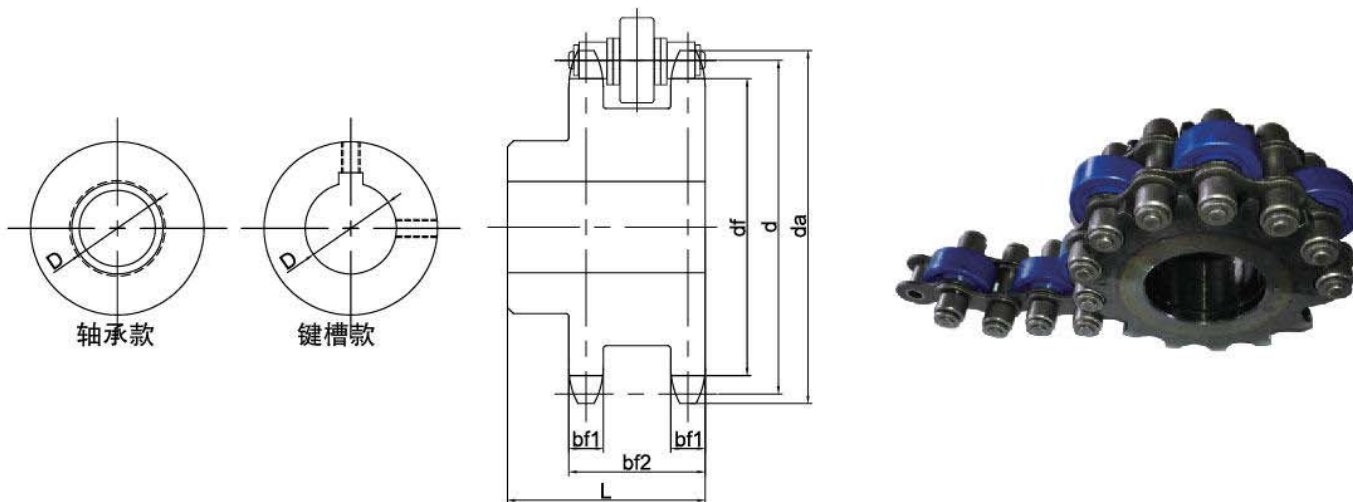

新球链号 Newball chain No.	节距 Pitch	滚子直径 Roller diameter	齿数 Number of teeth	系数 coefficient	齿宽 Tooth width	排距 Transverse pitch	分度圆 Pitch circle	齿根圆 Root circle	齿顶圆 Tip circle	内孔直径 Diameter of bore	总厚度 Aggregate thickness
	P	d1	Z	K	bf1	bf2	d	df	da	D	L
尺寸单位mm											
08BS	12.7	8.51	9	2.9238	5.5	2.7	37.13	28.62	44	根据 客户 要求	根据 客户 要求
	12.7	8.51	10	3.2361			41.10	32.59	47		
	12.7	8.51	11	3.5494			45.08	36.57	51		
	12.7	8.51	12	3.8637			49.07	40.56	55		
	12.7	8.51	13	4.1786			53.07	44.56	59		
	12.7	8.51	14	4.494			57.07	48.56	63		
	12.7	8.51	15	4.8097			61.08	52.57	67		
	12.7	8.51	16	5.1258			65.10	56.59	71		
	12.7	8.51	17	5.4422			69.12	60.61	75		
	12.7	8.51	18	5.7588			73.14	64.63	80		
	12.7	8.51	19	6.0755			77.16	68.65	84		
12.7	8.51	20	6.3925	81.18	72.67	88					
只列举到20齿，齿数可根据客户要求定做											
12BS	19.05	12.07	9	2.9238	11.3	44.5	55.70	43.63	65	根据 客户 要求	根据 客户 要求
	19.05	12.07	10	3.2361			61.65	49.58	71		
	19.05	12.07	11	3.5494			67.62	55.55	77		
	19.05	12.07	12	3.8637			73.60	61.53	83		
	19.05	12.07	13	4.1786			79.60	67.53	89		
	19.05	12.07	14	4.494			85.61	73.54	95		
	19.05	12.07	15	4.8097			91.62	79.55	101		
	19.05	12.07	16	5.1258			97.65	85.58	107		
	19.05	12.07	17	5.4422			103.67	91.60	113		
	19.05	12.07	18	5.7588			109.71	97.64	119		
	19.05	12.07	19	6.0755			115.74	103.67	125		
19.05	12.07	20	6.3925	121.78	109.71	131					
只列举到20齿，齿数可根据客户要求定做											

# 短节距倍速输送链链轮

Short pitch Speed-fold conveyor chain sprocket

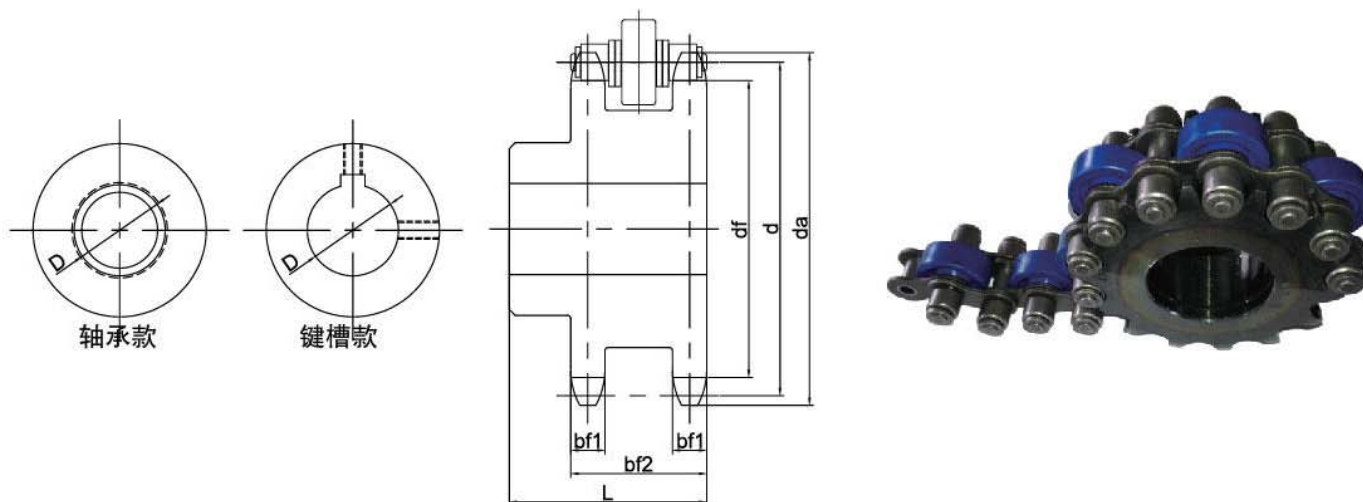

新球链号 Newball chain No.	节距 Pitch	滚子直径 Roller diameter	齿数 Number of teeth	系数 coefficient	齿宽 Tooth width	排距 Transverse pitch	分度圆 Pitch circle	齿根圆 Root circle	齿顶圆 Tip circle	内孔直径 Diameter of bore	总厚度 Aggregate thickness
	P	d1	Z	K	bf1	bf2	d	df	da	D	L
尺寸单位mm											
16BS	25.4	15.88	9	2.9238	15	65	74.26	58.38	86	根据 客户 要求	根据 客户 要求
	25.4	15.88	10	3.2361			82.20	66.32	94		
	25.4	15.88	11	3.5494			90.15	74.27	102		
	25.4	15.88	12	3.8637			98.14	82.26	110		
	25.4	15.88	13	4.1786			106.14	90.26	118		
	25.4	15.88	14	4.494			114.15	98.27	126		
	25.4	15.88	15	4.8097			122.17	106.29	134		
	25.4	15.88	16	5.1258			130.20	114.32	142		
	25.4	15.88	17	5.4422			138.23	122.35	150		
	25.4	15.88	18	5.7588			146.27	130.39	158		
	25.4	15.88	19	6.0755			154.32	138.44	166		
	25.4	15.88	20	6.3925			162.37	146.49	174		

只列举到20齿，齿数可根据客户要求定做